

**WIRING DIAGRAM-IN-CAB FUEL TANK**

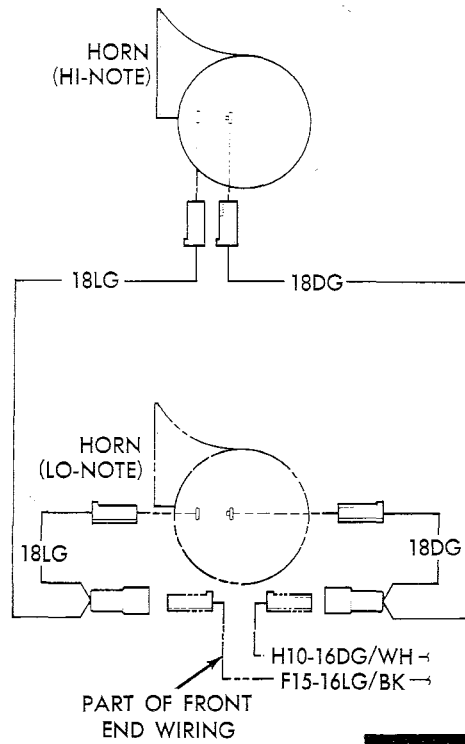

**WIRING DIAGRAM - DUAL HORNS**

COLOR CODE	
BK	BLACK
BN	BROWN
DB	DARK BLUE
LB	LIGHT BLUE
BL	BLUE
DG	DARK GREEN
LG	LIGHT GREEN
GN	GREEN
OR	ORANGE
PK	PINK
RE	RED
TN	TAN
PU	PURPLE
GR	GRAY
WH	WHITE
YE	YELLOW
WIRES WITH TRACERS TYPICAL EXAMPLES	
BK/WH	BLACK WIRE WITH WHITE TRACER
YE/BK	YELLOW WIRE WITH BLACK TRACER

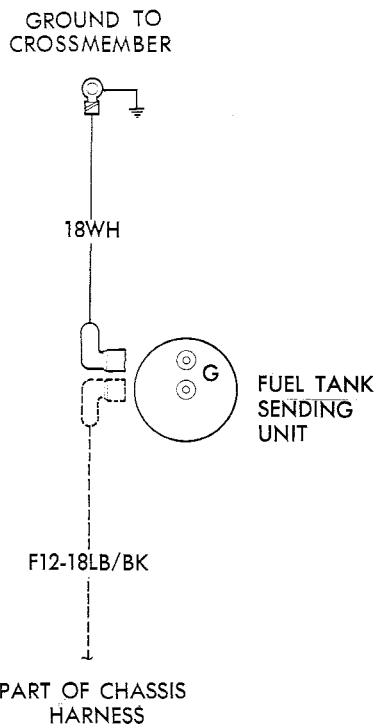

**36 GALLON FUEL TANK (PLASTIC)**

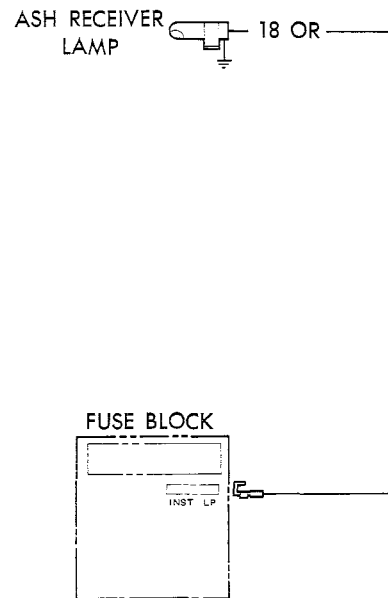

**WIRING DIAGRAM - ASH RECEIVER LAMP**

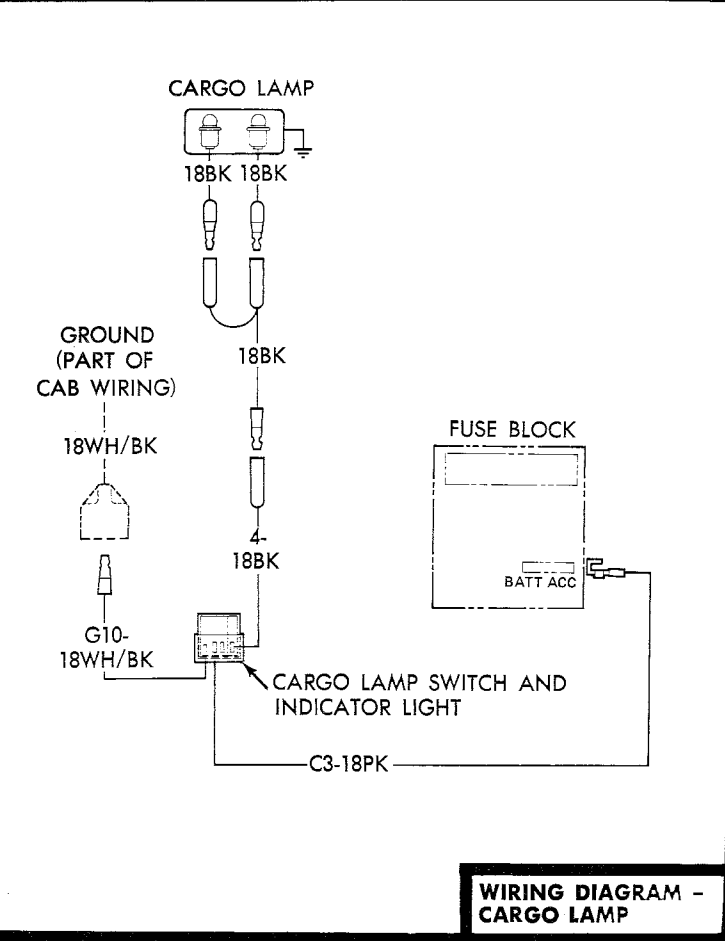
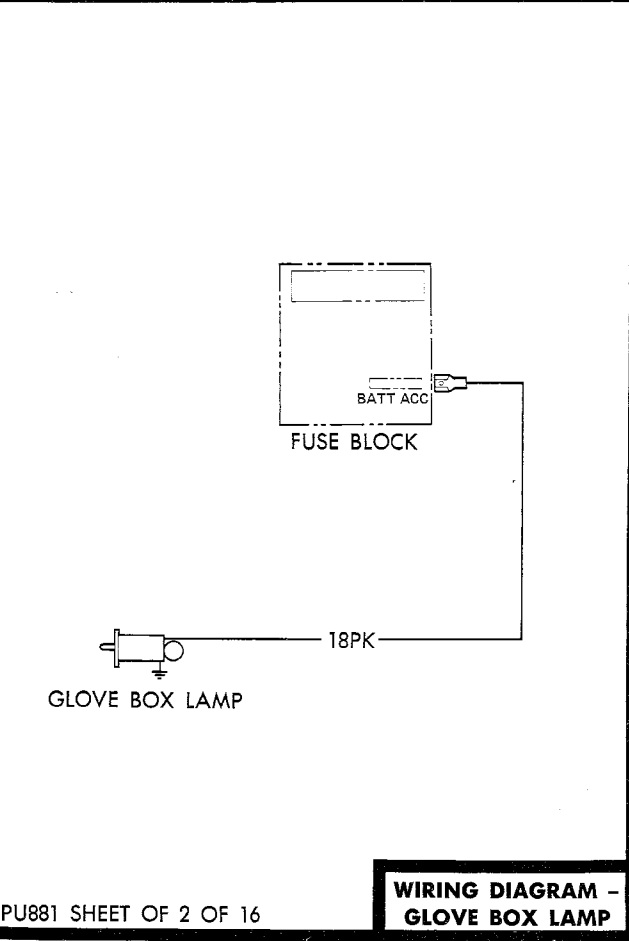
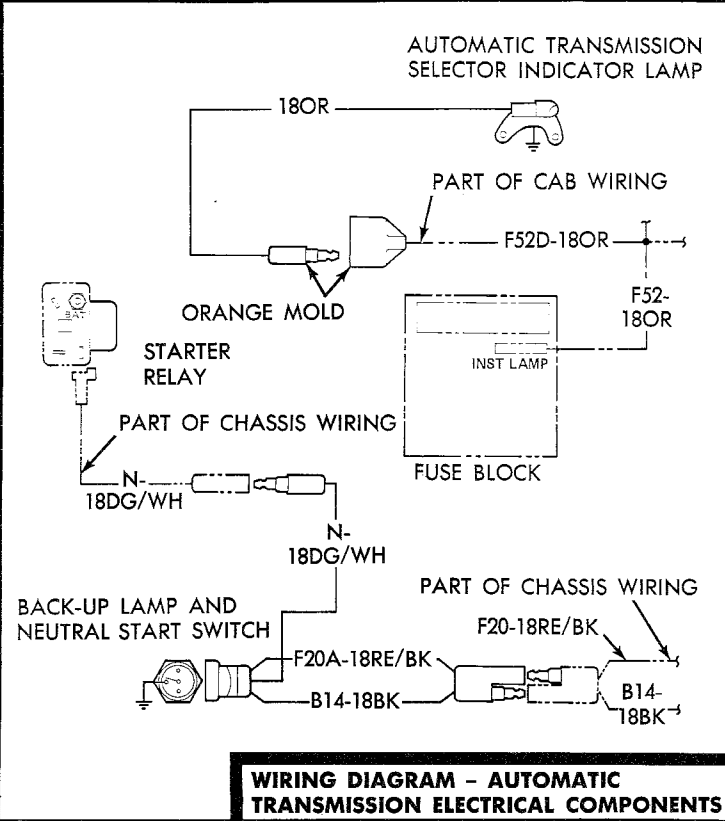
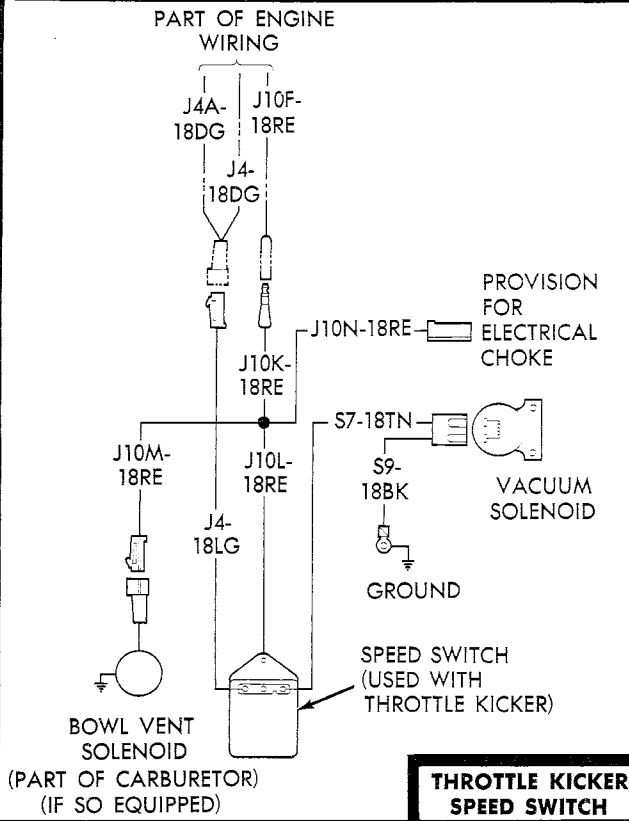

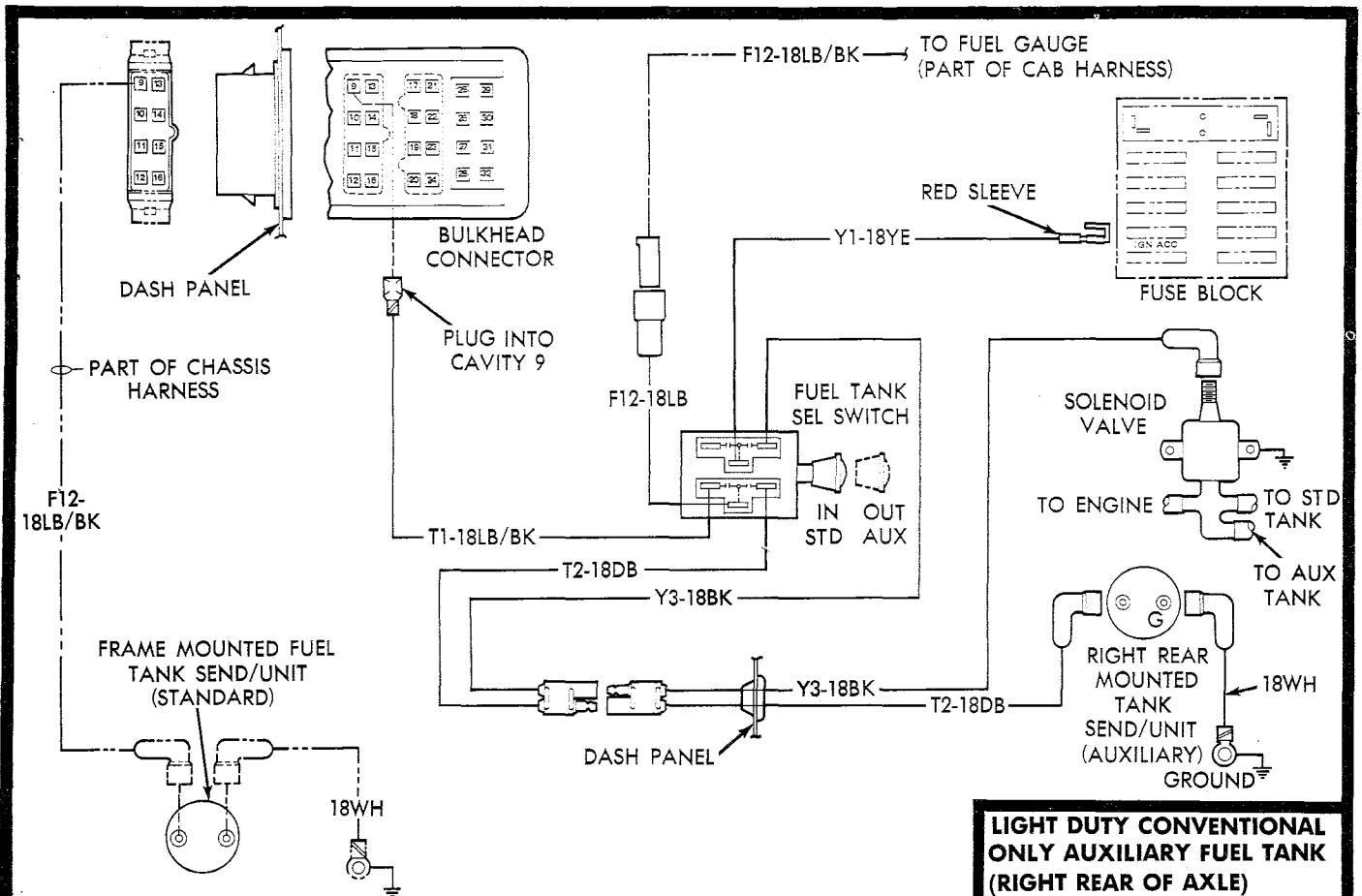

**LIGHT DUTY CONVENTIONAL ONLY AUXILIARY FUEL TANK (RIGHT REAR OF AXLE)**

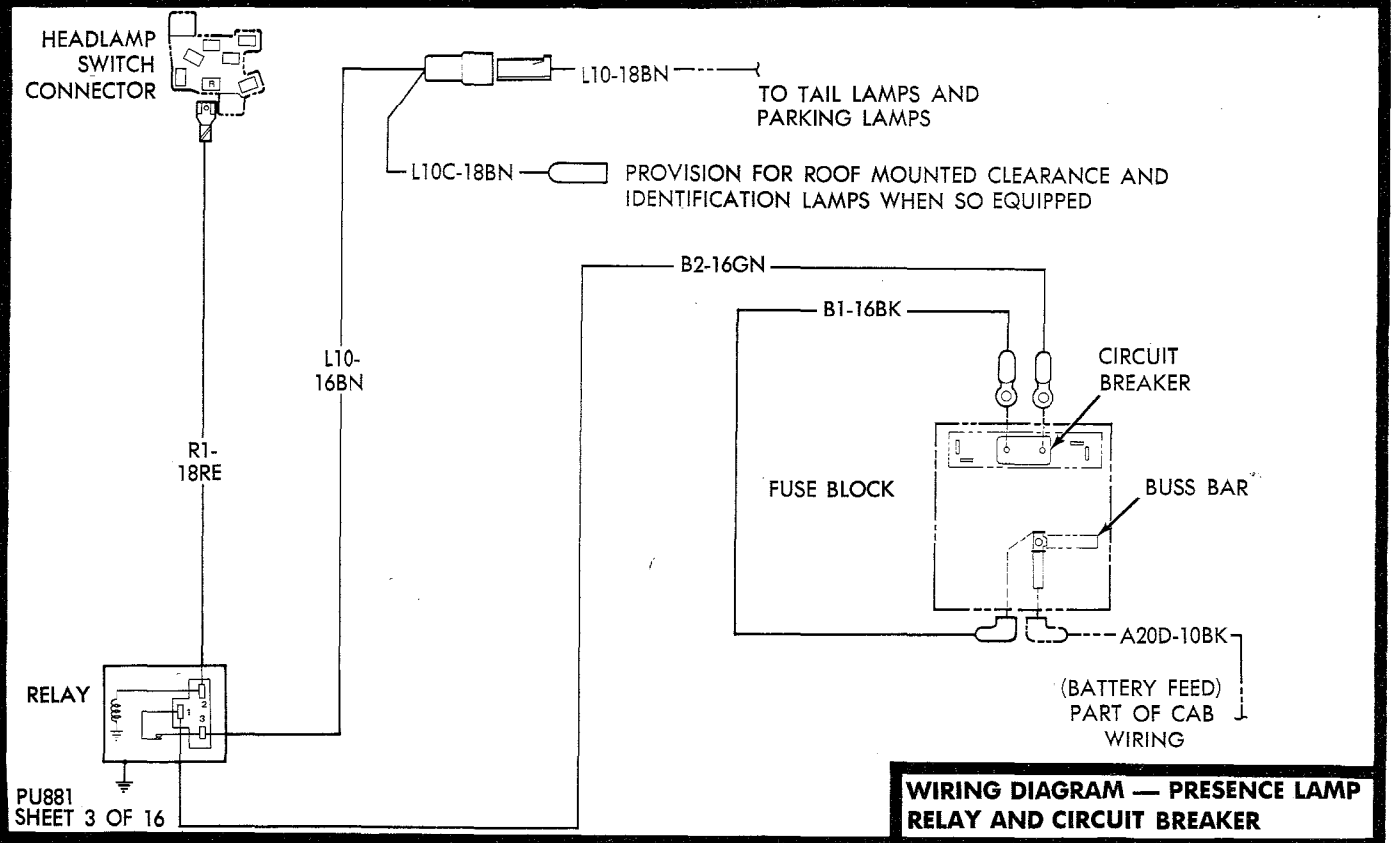

**WIRING DIAGRAM — PRESENCE LAMP RELAY AND CIRCUIT BREAKER**

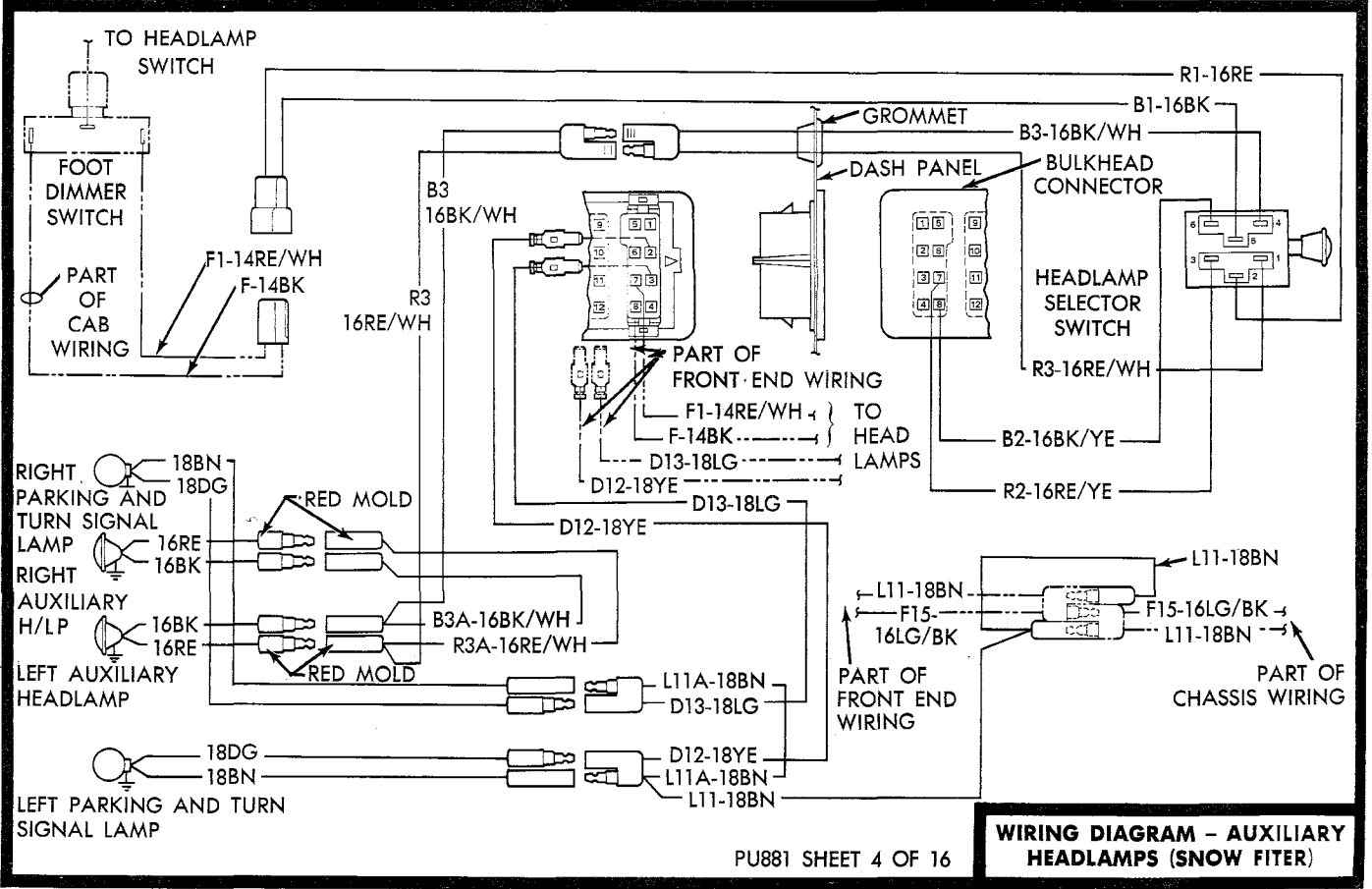
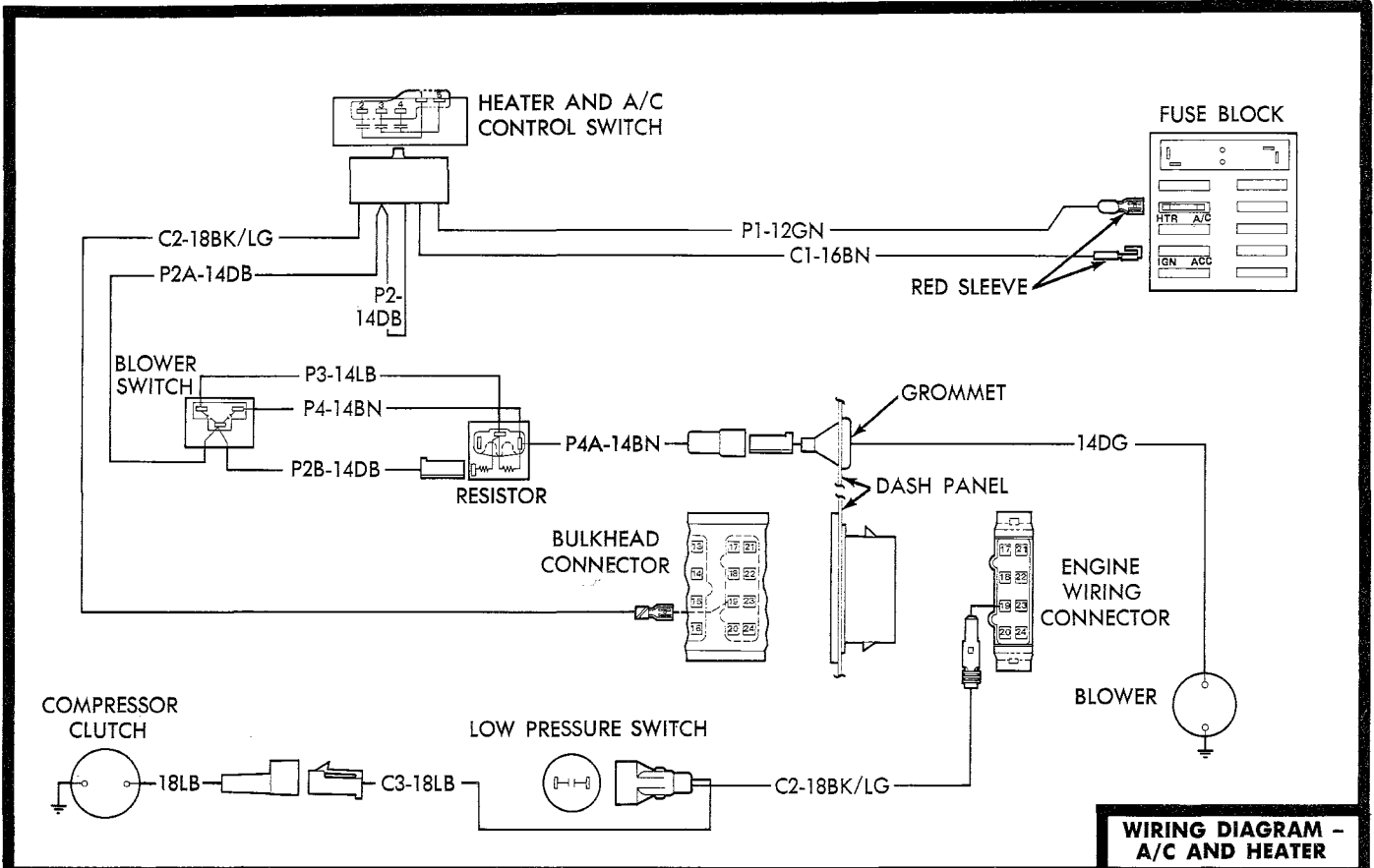

**Auxiliary Wiring Diagrams**

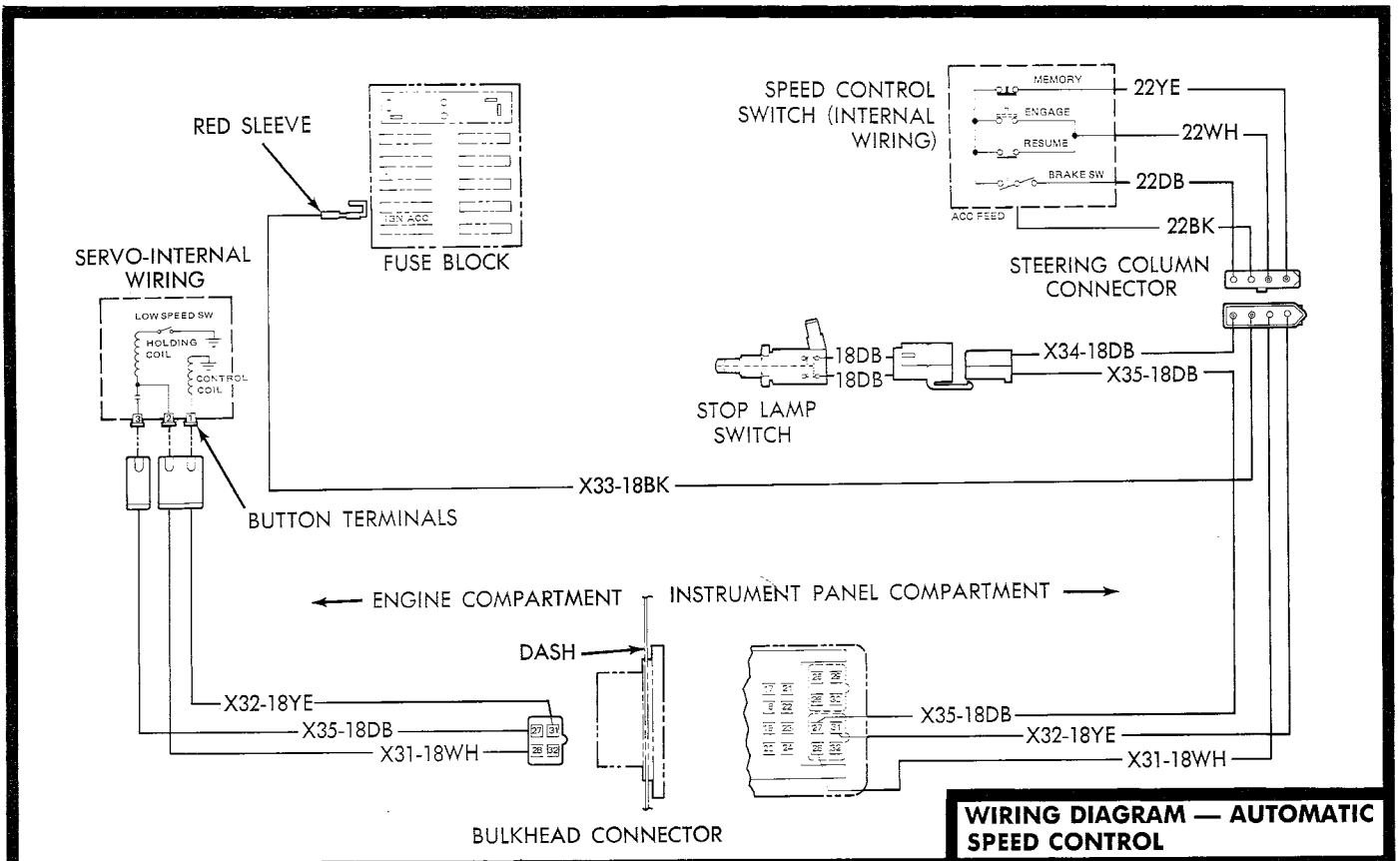

**WIRING DIAGRAM — AUTOMATIC SPEED CONTROL**

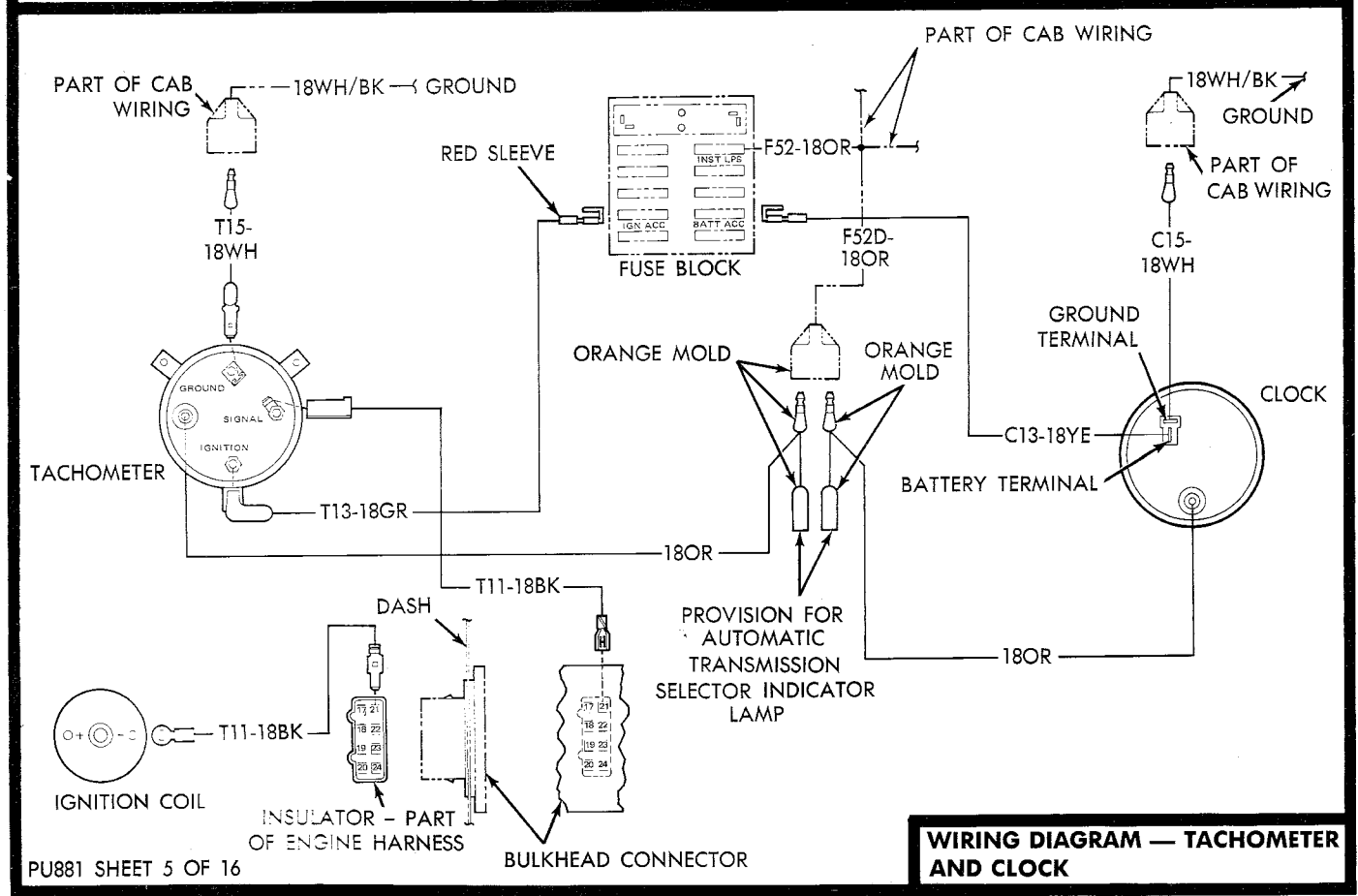

**WIRING DIAGRAM — TACHOMETER AND CLOCK**

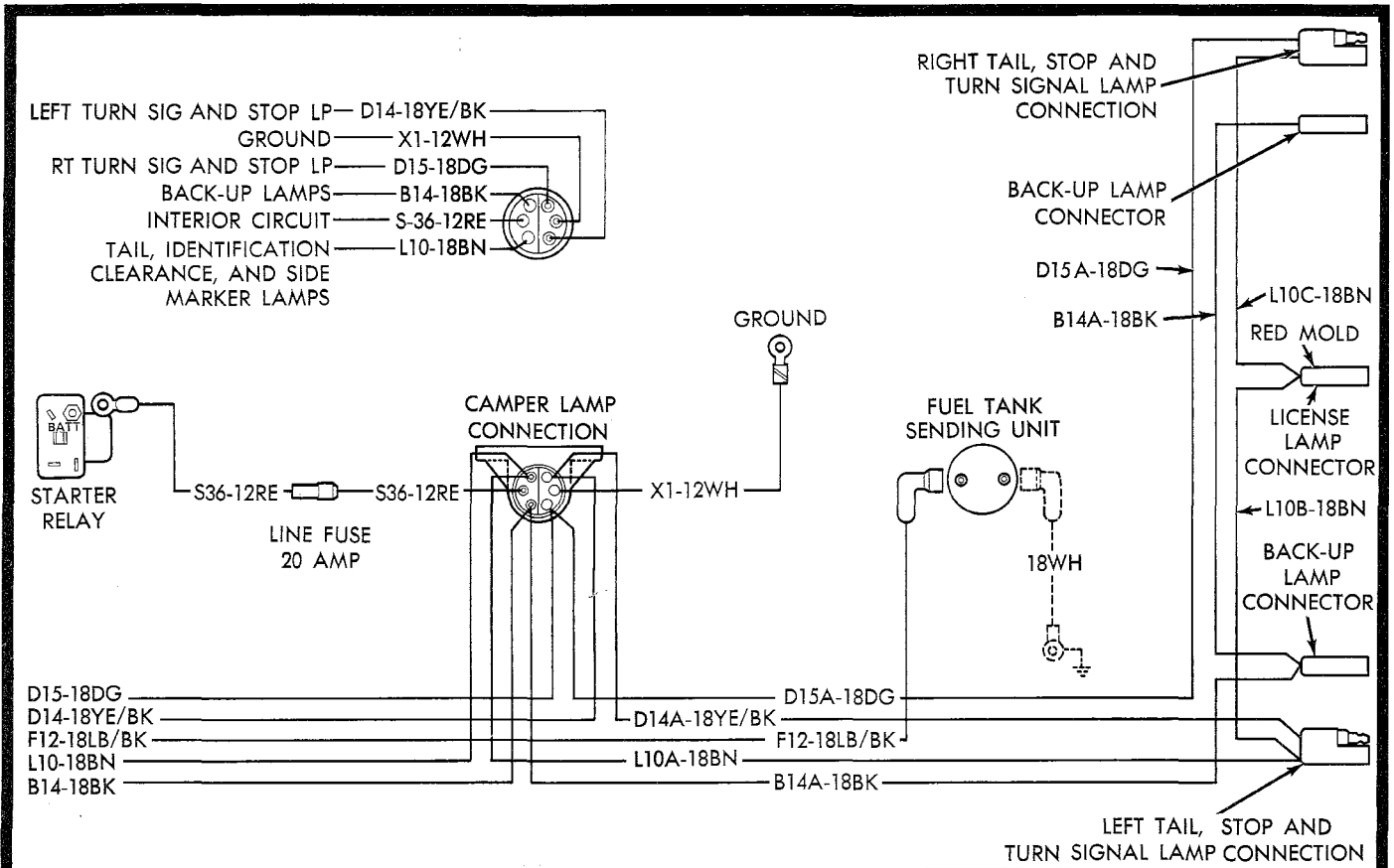

**WIRING DIAGRAM - CAMPER CHASSIS**

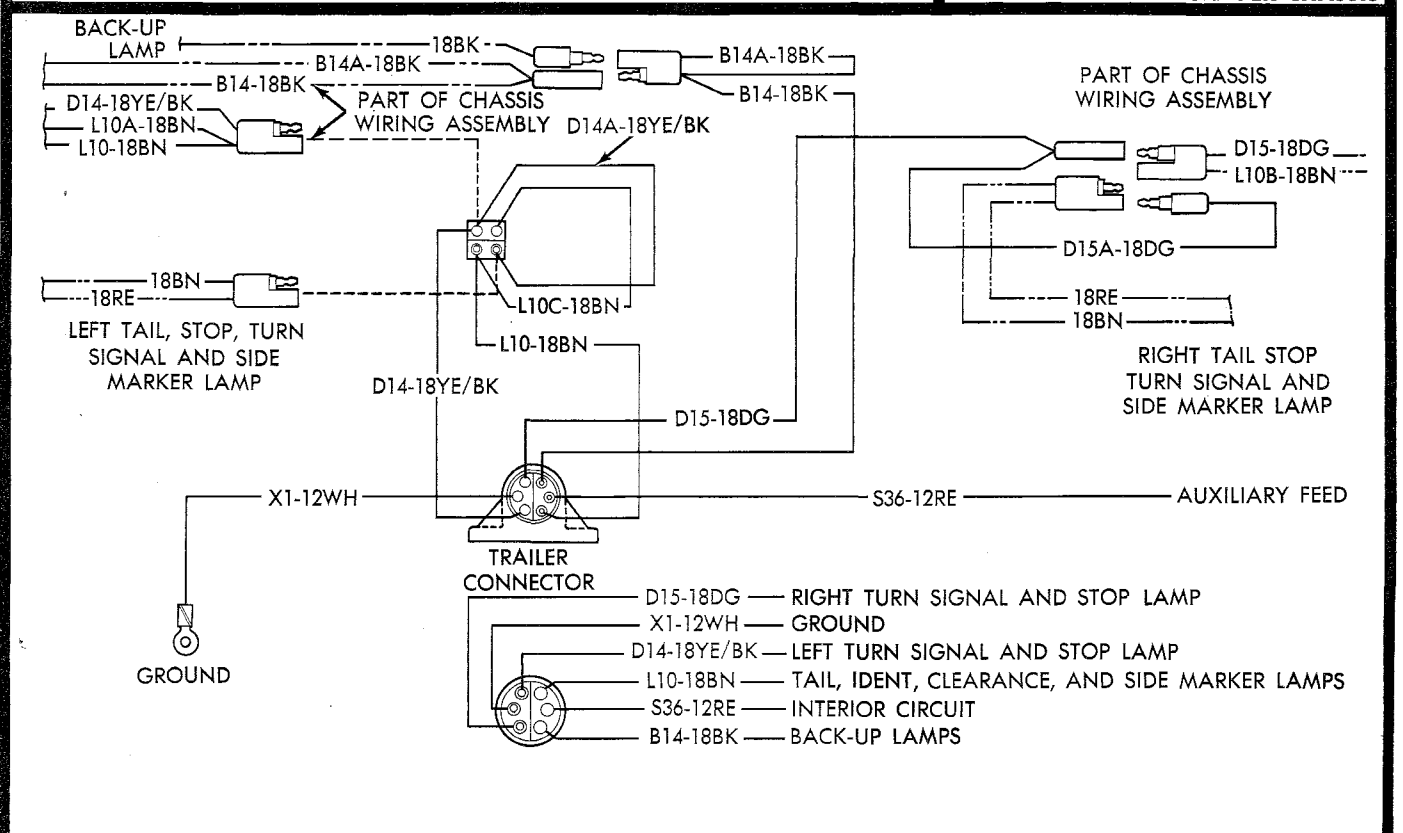

**WIRING DIAGRAM - TRAILER TOWING**

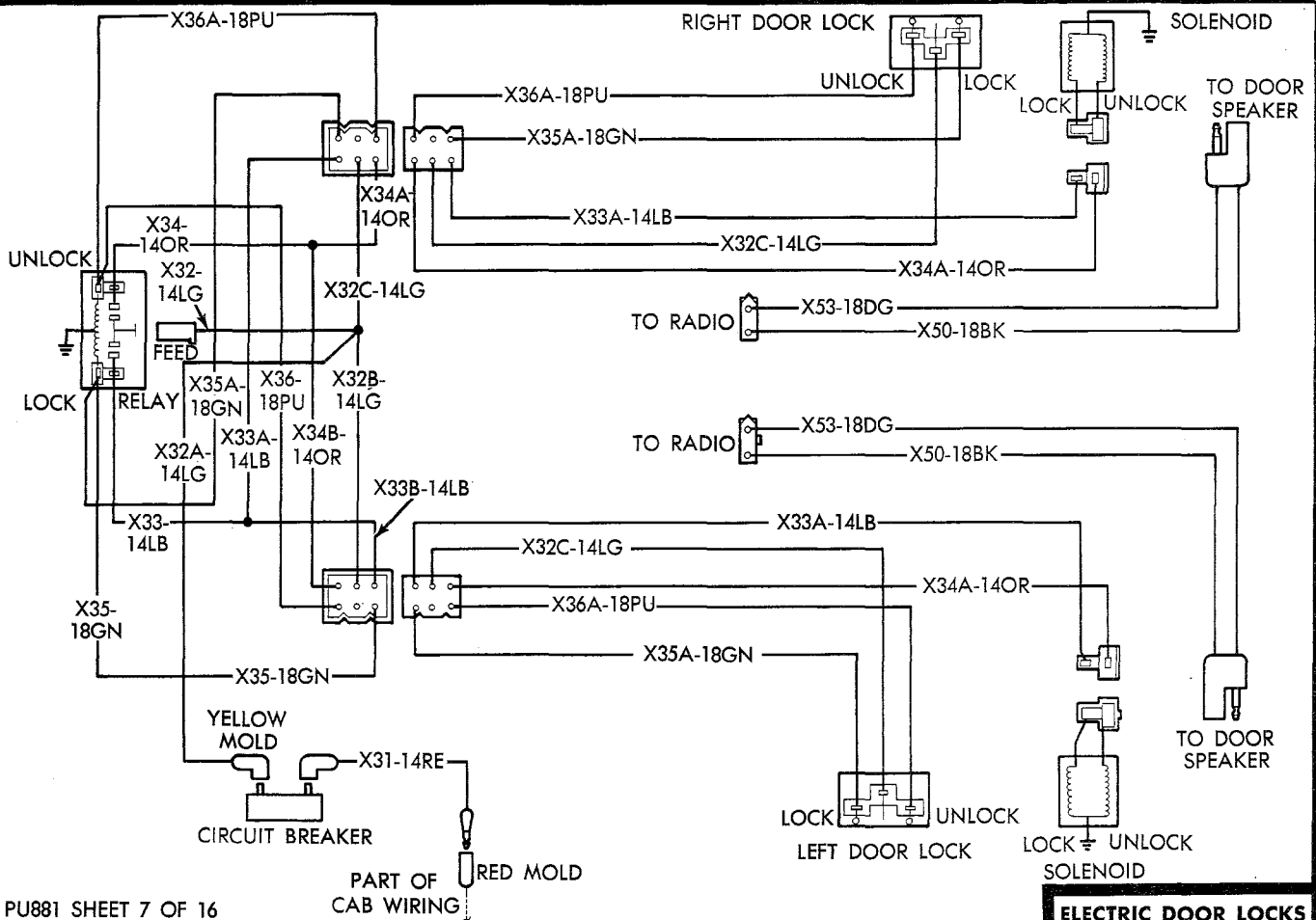
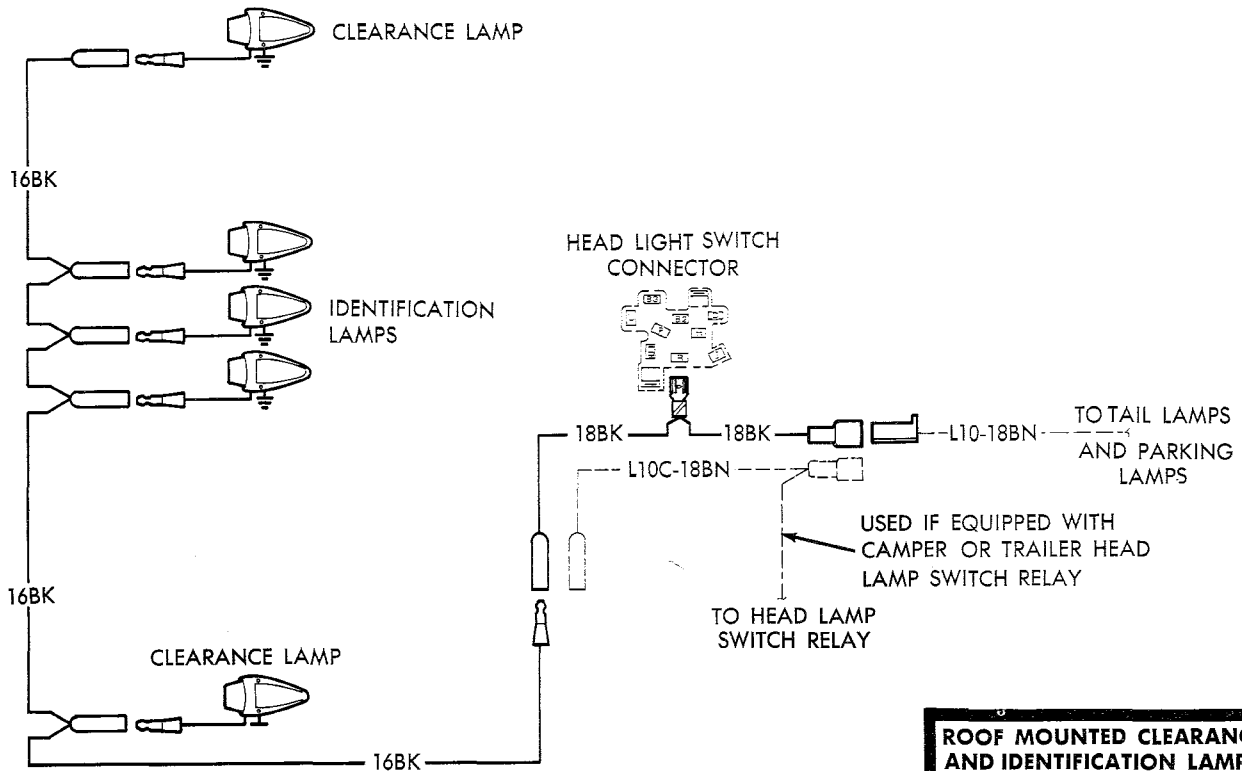

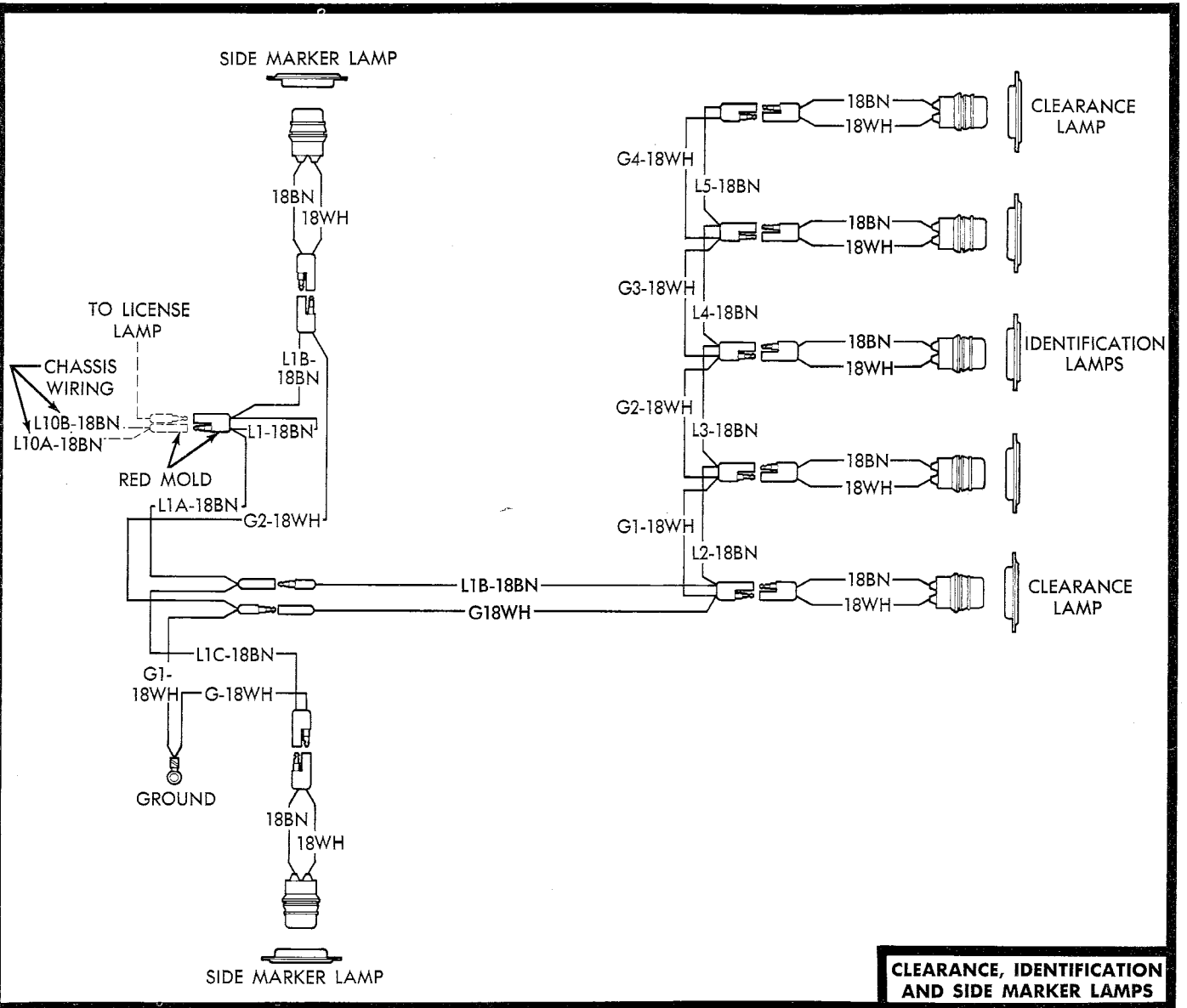

**CLEARANCE, IDENTIFICATION AND SIDE MARKER LAMPS**

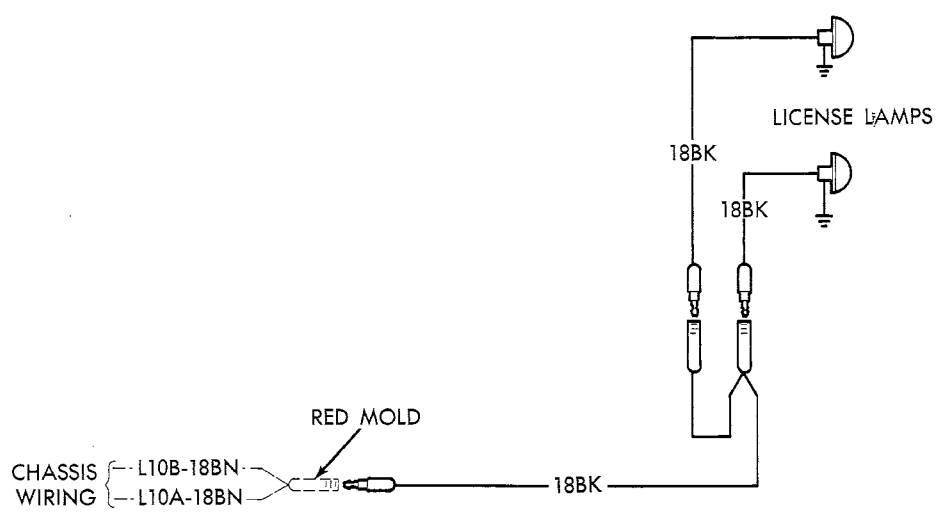

**LICENSE LAMPS**





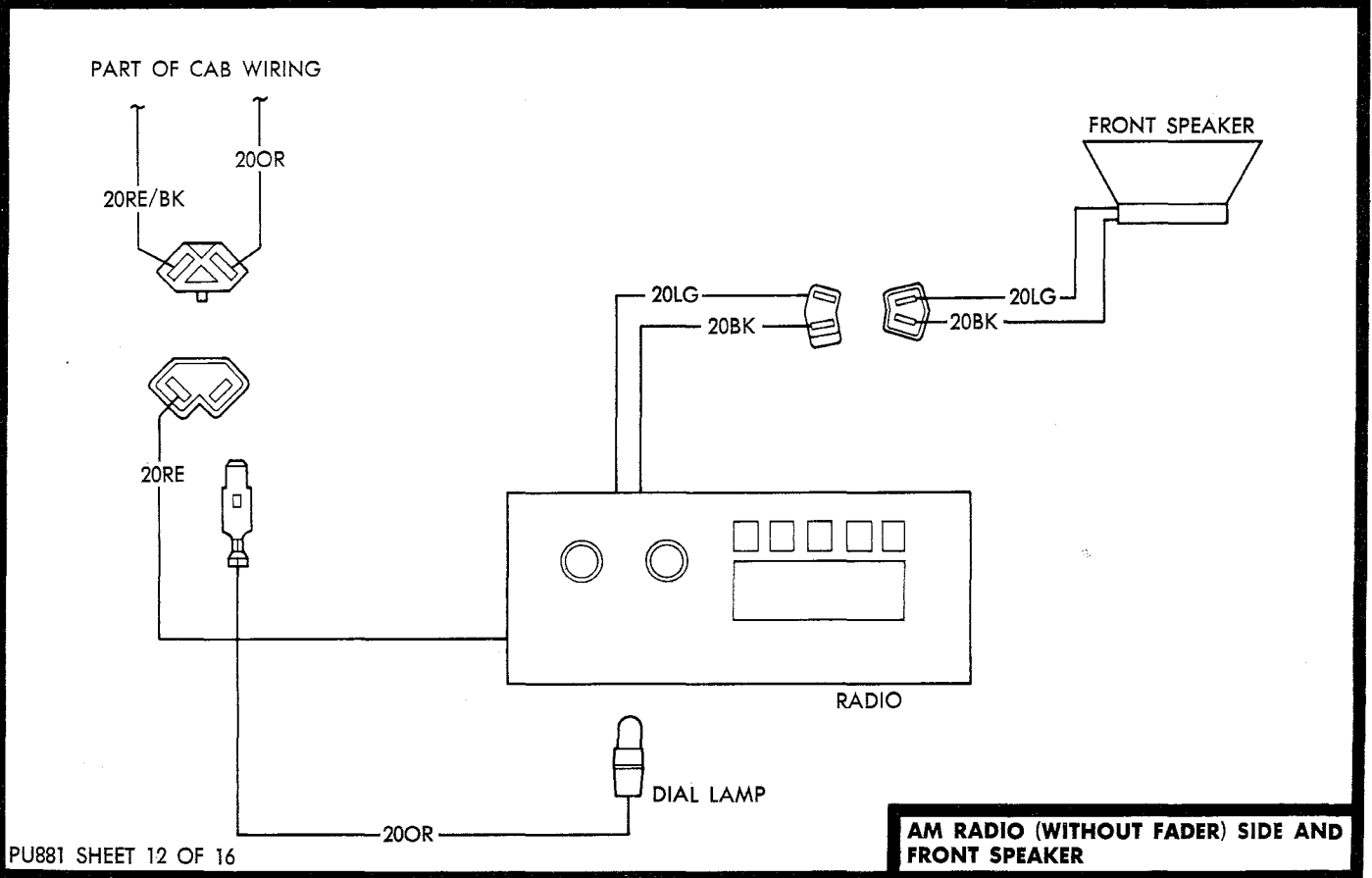
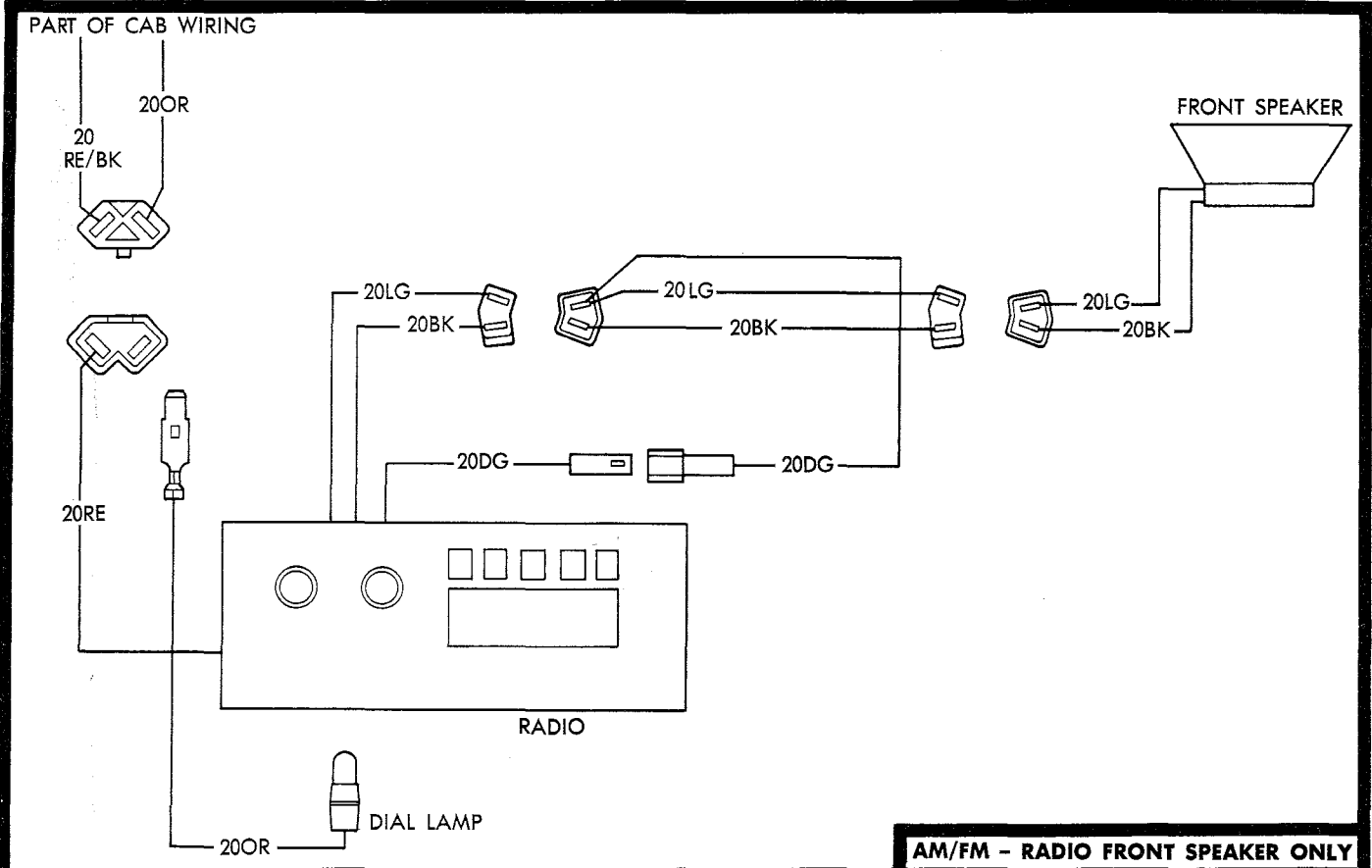

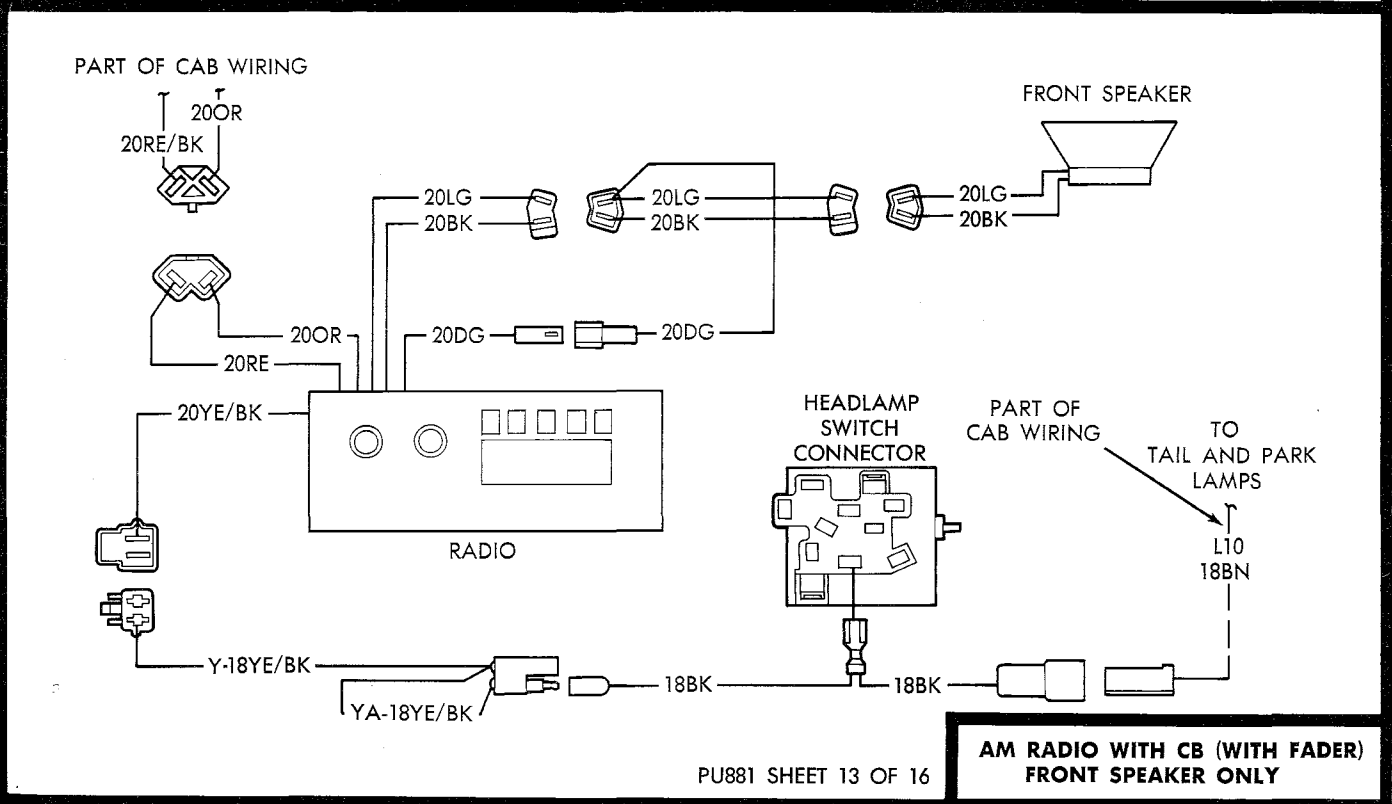
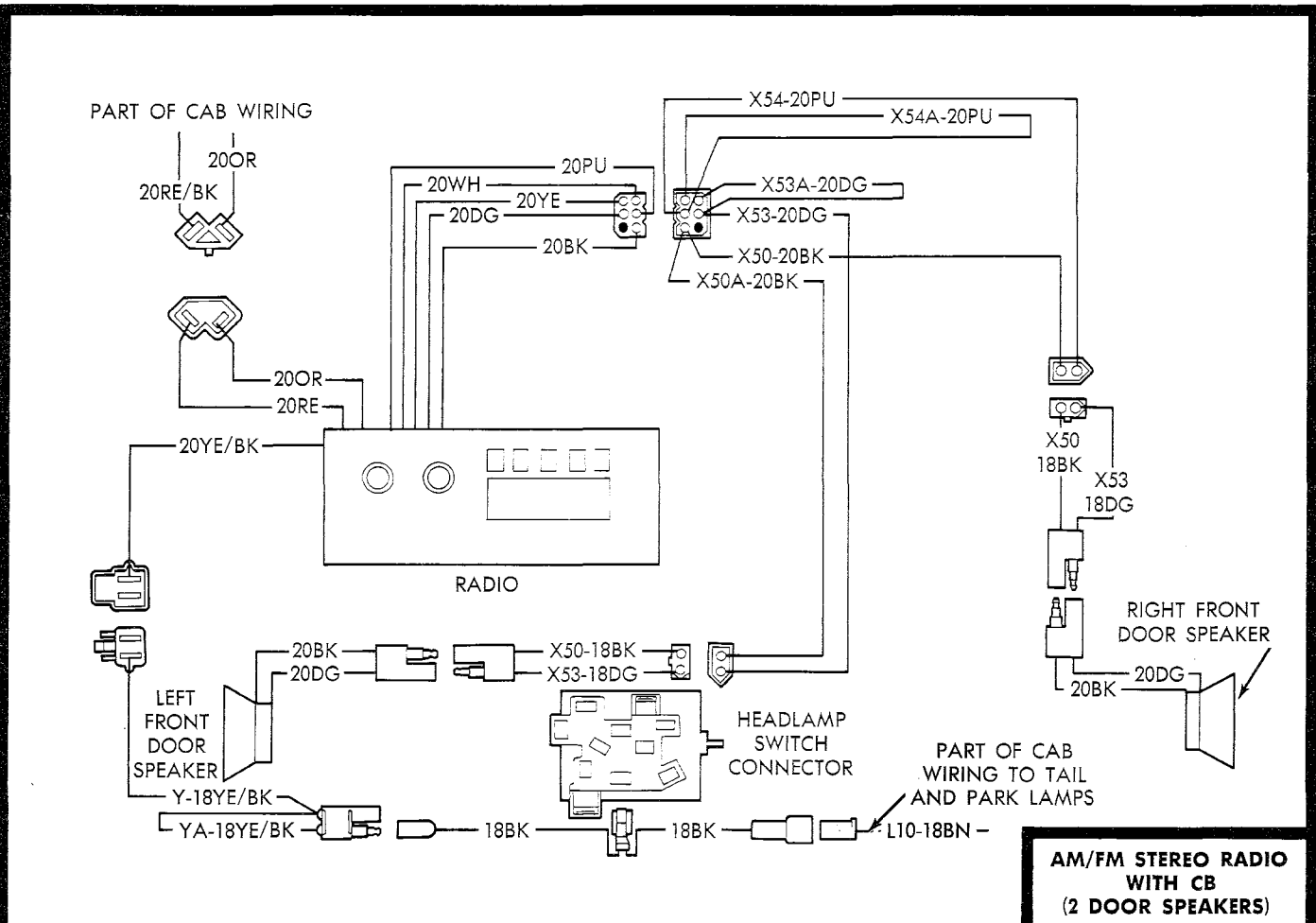

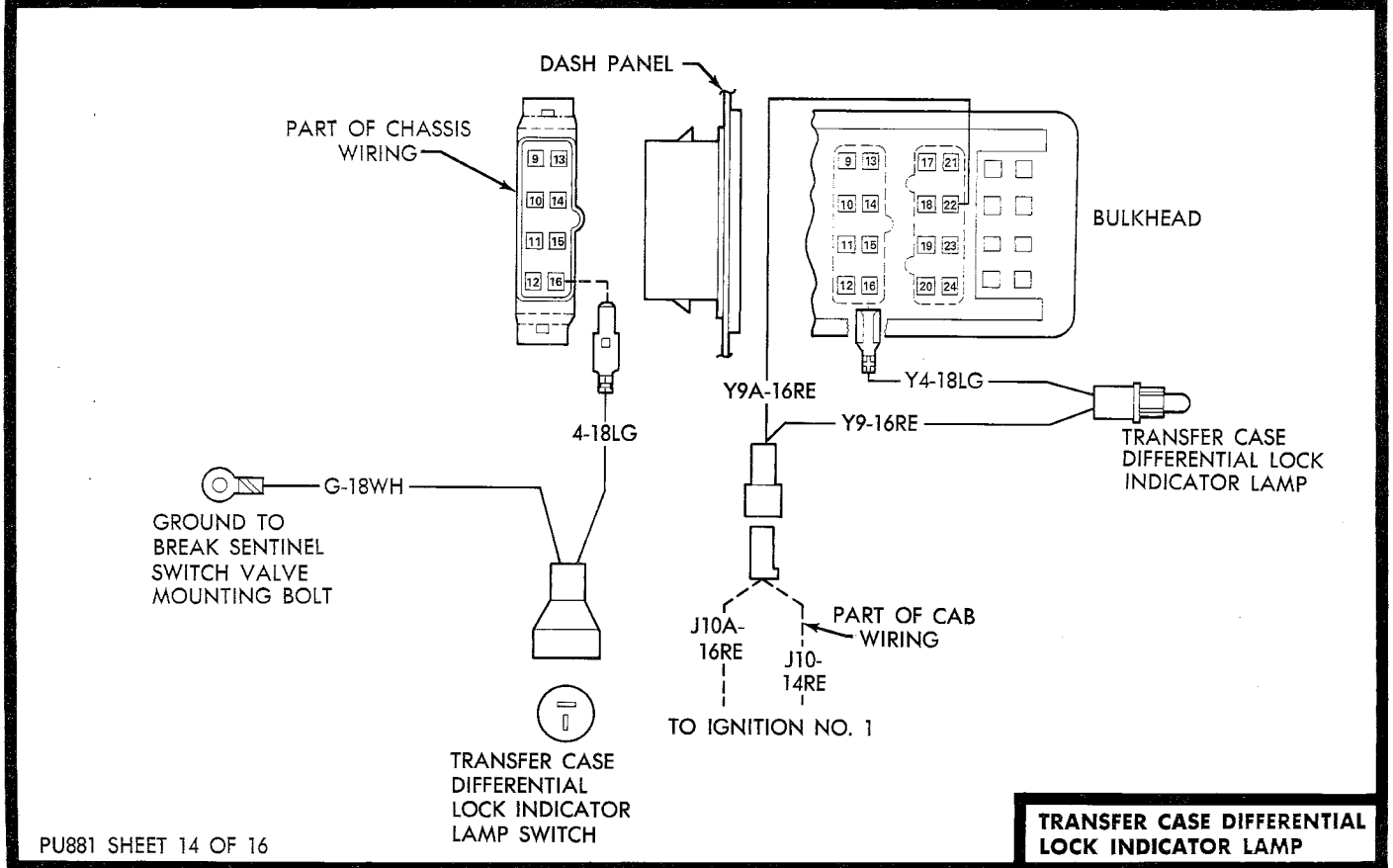
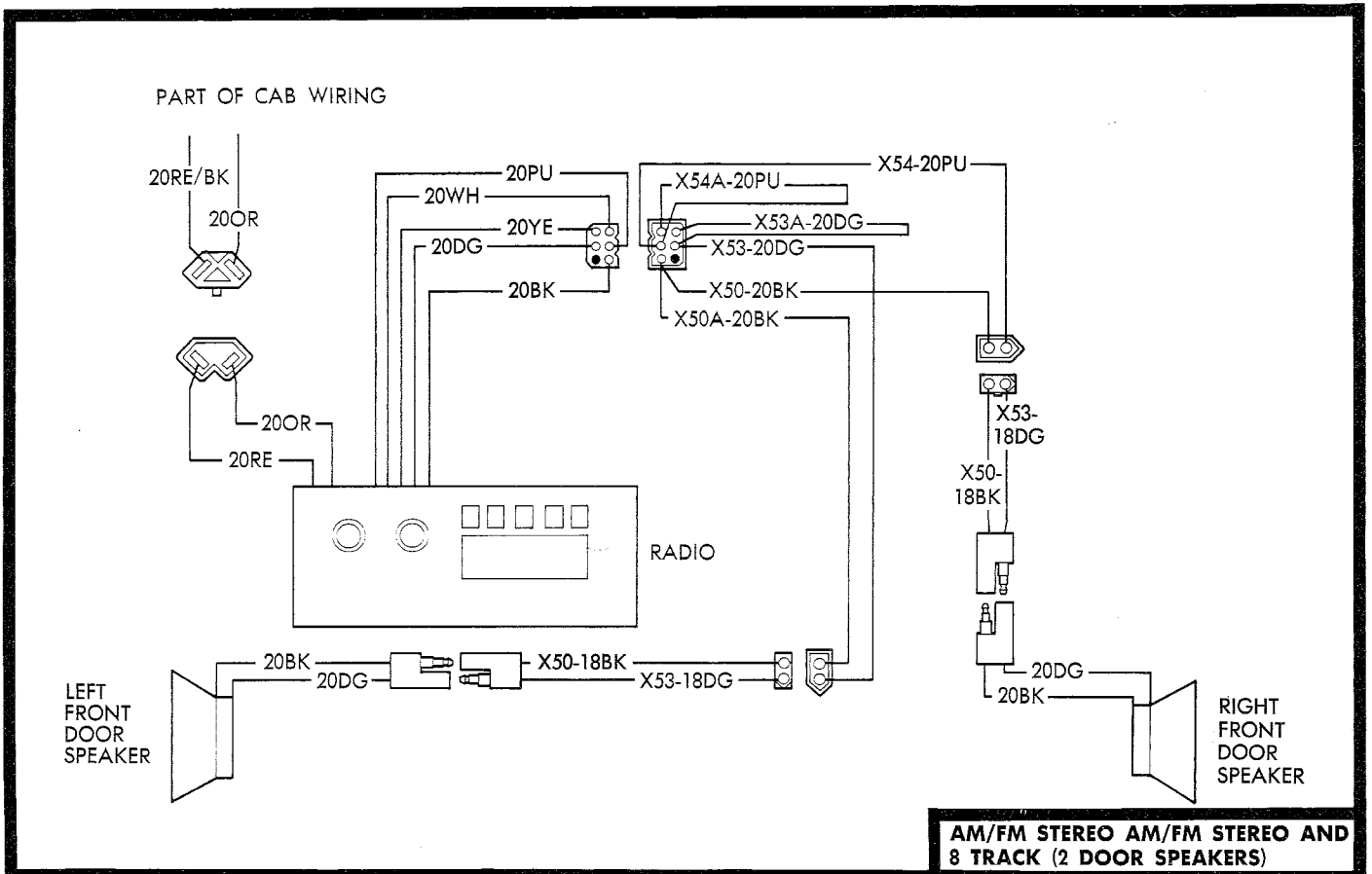

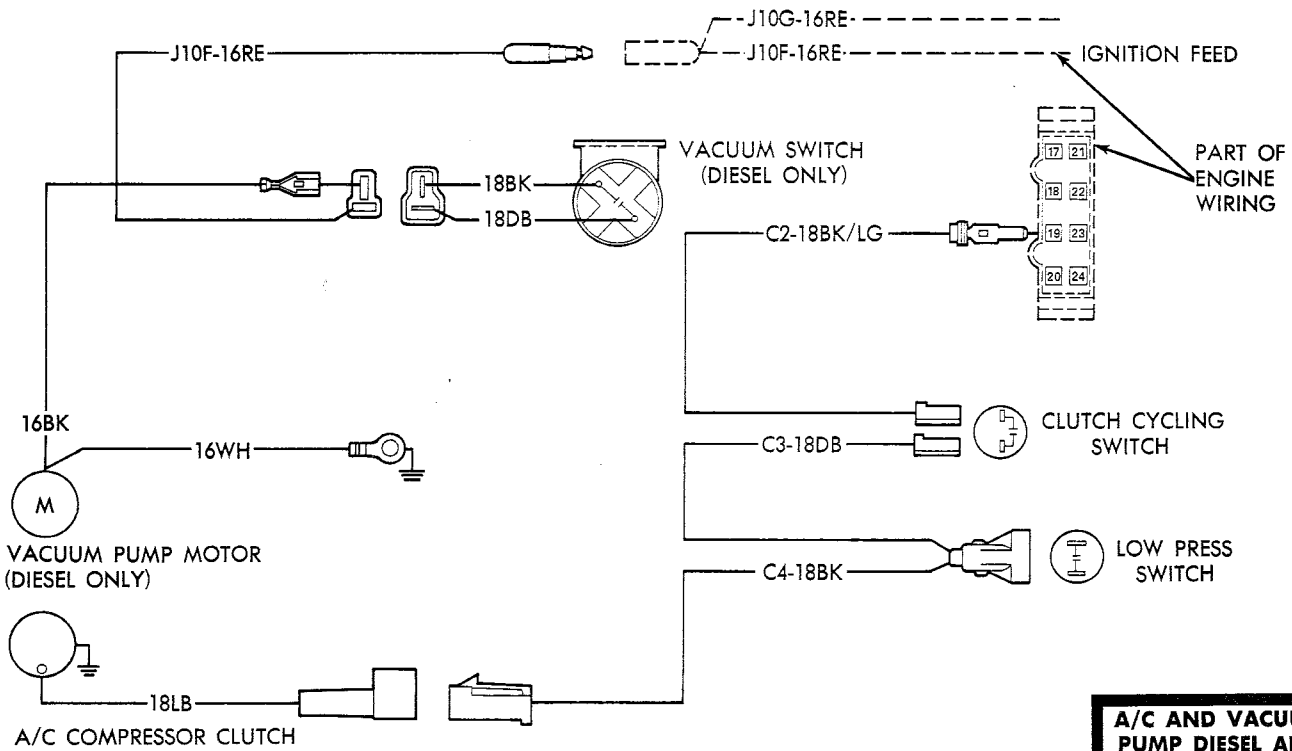

**A/C AND VACUUM PUMP DIESEL AND 6 CYLINDER ENGINE**

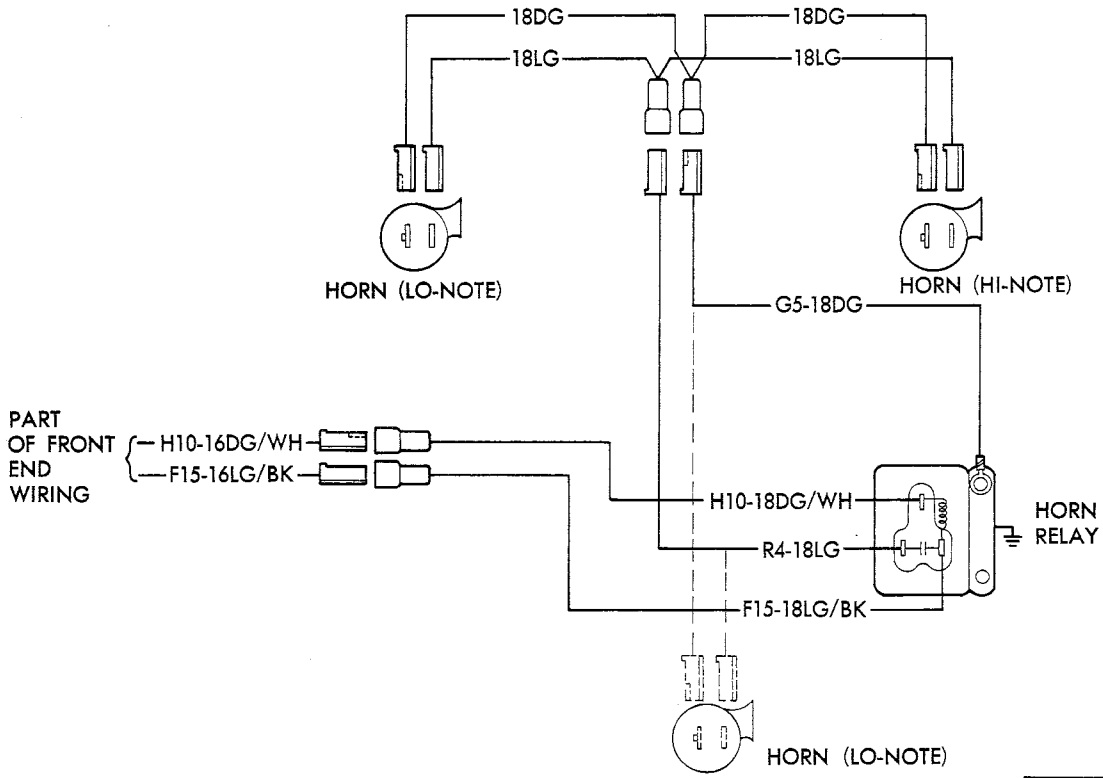

**HORN WITH RELAY SINGLE AND DUAL (TILT COLUMN)**

